



19, Gr.Floor,Shanta Industrial Premises Co-op Society Ltd, I.BPatel Road, Goregaon (East) Mumbai - 400063

Tel : 022-26858793 • Cell : 09821271748 • Telefax : 022-26852558

ACTUATOR OPERATED JACKETED BALL VALVE

Salient Features and Specialities:

- ✦ **Specially Designed for 300°C fluid**
- ✦ Positive shut off
- ✦ Longer life
- ✦ Quick in action
- ✦ No lubrication
- ✦ Visual on / off indication
- ✦ Compact design
- ✦ Corrosion resistant
- ✦ Low pressure drop
- ✦ Simplicity
- ✦ Available in both regular port & full port patterns

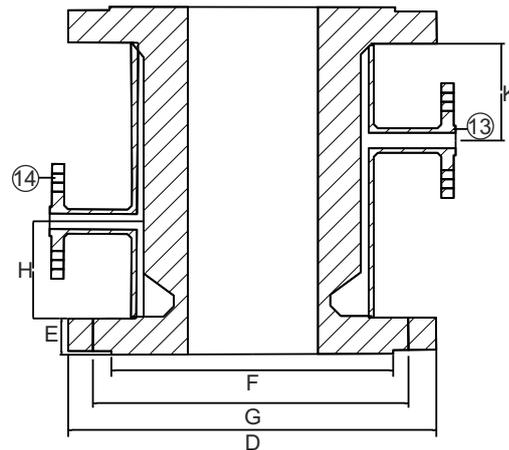
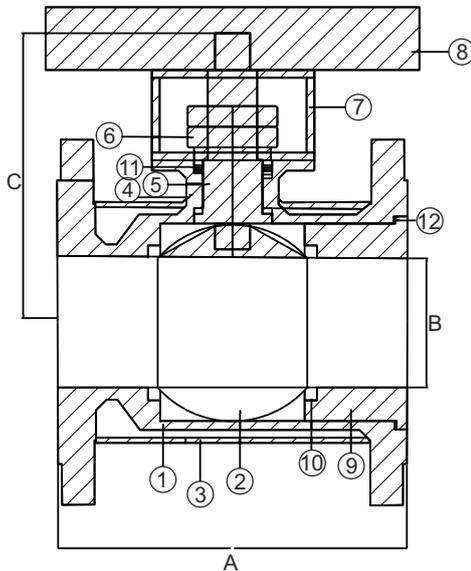

Sr. No.	NAME OF PARTS	MATERIAL
1	BODY	CF.8 / WCB.
2	BALL	A.I.S.I 304 / 316
3	JACKETPIPE	M.S./ SS304
4	BONNET	A.I.S.I S.S. 304/316
5	STEM	A.I.S.I. S.S.304/316
6	GLAND NUT	A.I.S.I S.S. 304
7	BREAKET	CF.8 / WCB.
8	ACTUATOR	ALUMINIUM
9	ADABTOR	CF.8 / WCB.
10	SEAT RING	PEEK
11	STEM PACKING	GLASS FIELD P.T.F.E
12	BODY SEAL	GLASS FIELD P.T.F.E
13	1"asa.150inletconect.	M.S.
14	1"asa.150inletconect.	M.S.

End Connections : Flanged

TEST PRESSURES IN PSIG		
HYDROSTATIC		AIR
BODY	SEAT	SEAT
30KG/CM2	21KG/CM2	7KG/CM2

SIZE	A	B	C	D	E	F	G	H	K
1"x11/2"	165	25	75	127	14	73	98.5 PCD 14holex4no	60	60
11/2"x2"	178	38	80	152	16	92	120.5 PCD 18holex4no	60	60
2"x3"	203	50	118	190	18	127	152.5 PCD 19holex4no	63	63
3"x4"	229	75	216	229±	124	157	190.5 PCD 19holex8no	63	63
4"x6"	267	100	225	280±	125	216	241.5 PCD 22holex8no	75	75
6"x 10"	292	150	340	406.5	30	324	362.5 PCD 25holex12no	95	95